



Promix engineering and
production
center

**DESIGNED AND
MANUFACTURED
IN RUSSIA**



You have an idea —
we have a solution

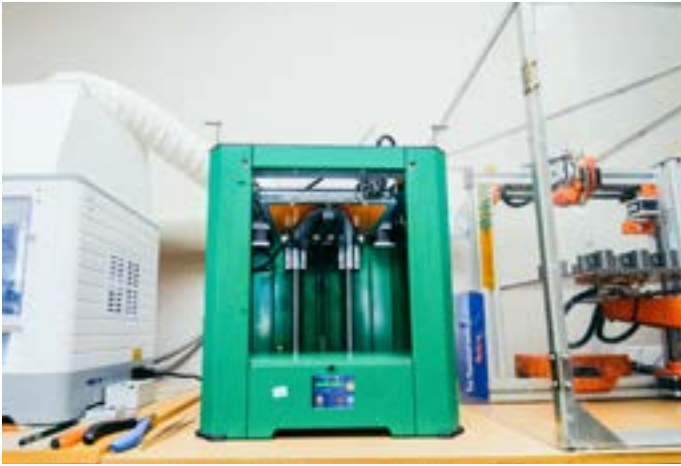

Promix engineering and
production
center



Reliable and
technology-savvy
partner

Promix

engineering and
production
center

Promix is a modern Russian engineering and production center. The company specializes in the development, testing and serial production of electromechanical locks, automation and electronic equipment for various purposes.

Since 2004, PROMIX has produced more than 1,000,000 items at its own plant in Smolensk using domestic and imported raw materials and parts.

The design department of the company constantly develops new products and opens up new areas of activity.

promix-center.ru

Established in
2004

Contents

1. Company history.....	2
2. Facts and figures.....	3
3. Our mission.....	4
4. Our business.....	5
5. Services and production.....	6
6. Research and Development	8
7. Patents	9
8. Products	10
9. Sales geography	22
10. 10 reasons to work with us	23
11. Clients	24
12. Contact details	26

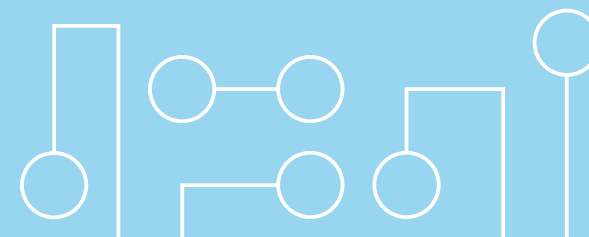

Company history

in figures and facts

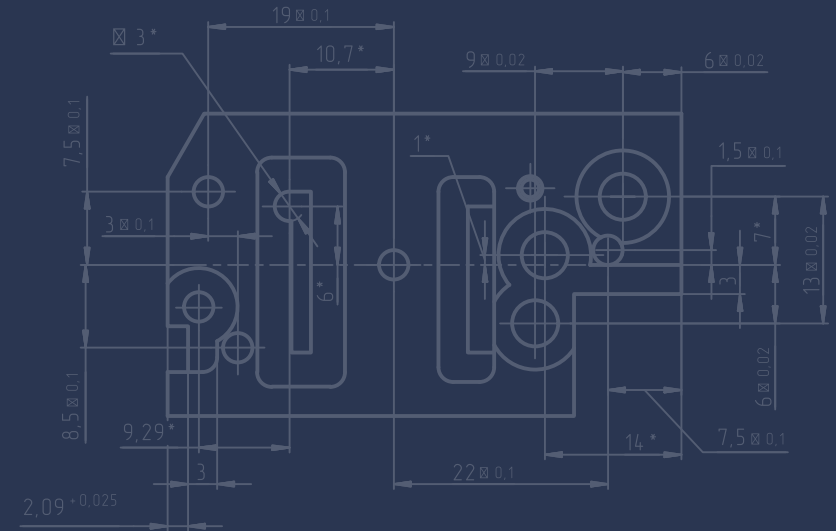

2004

Foundation of the company by Doctor of Engineering Sciences, Professor A. E. Malinovsky. Development, patenting and manufacturing of an electromechanical lock for a refrigerated cabinet.

2007

Setting-up of a design department and pilot production. Expansion of the product range under the Sheriff brand. Establishment of new areas of activity.

2009

Start of product supply directly to the Metalprio Solutions plant's conveyor, Kaliningrad (Derby, Caravell brands).

Cooperation with the Frigoglass (Frigorex) factory that produces refrigerated cabinets for the Coca-Cola company. Almost all Coca-Cola refrigerators have Promix electromechanical locks installed.

2004-2008

Setting-up of a retail dealer network throughout Russia.

2008

Export of products outside the CIS (Italy, Australia). Product supplies directly to the Sovitalprod mash plant's conveyor for PepsiCo (POLAIR brand).

2010

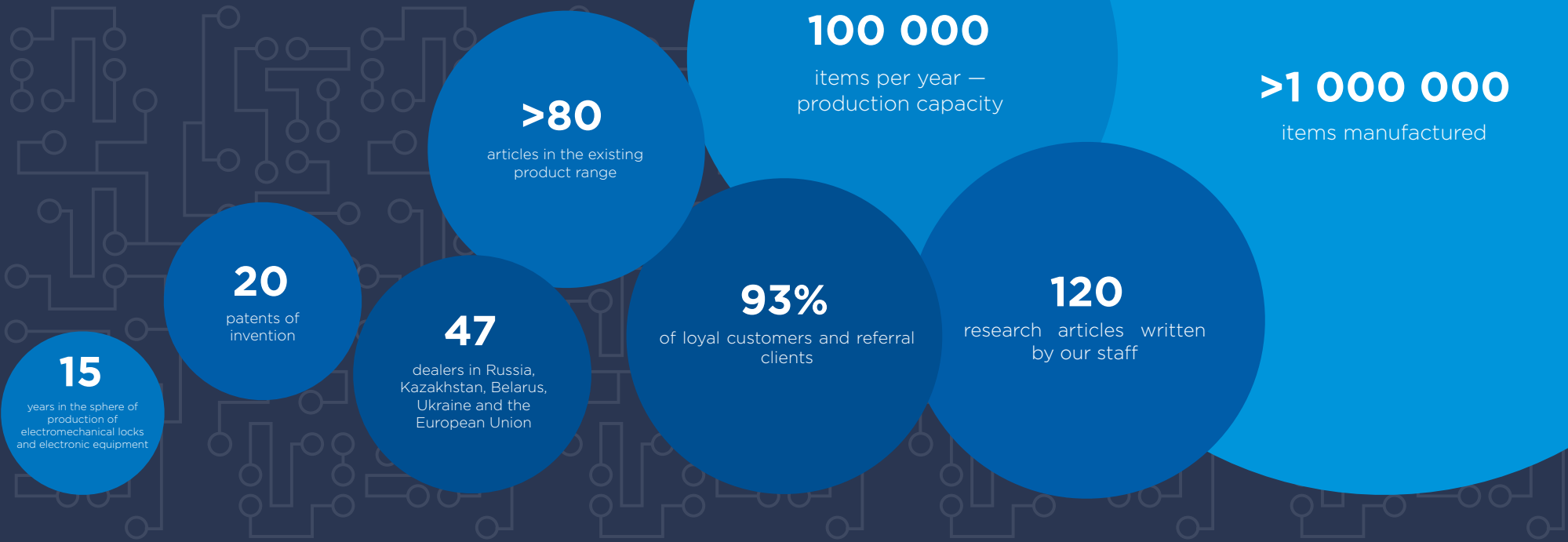

2013

Universiade in Kazan — ATM self service areas were equipped with the Sheriff-Bank system. Direct product supplies to the BALTIKA Brewery (Carlsberg Group).

2016

Development and serial production of electronic locks for the manufacturer of refrigeration equipment “UBC Group”. Market launch of the brand “Klimat” — equipment for air conditioners. The first Russian automated bicycle parking “Sheriff-Velo” was developed.

2018

Expansion of the dealer network. The company received 5 new patents of invention. The company was listed among “100 best enterprises of Russia”.

The SHERIFF-LOCKER system was installed at sports facilities during the preparation for the World Cup 2018. The company’s products were represented throughout Russia, in Kazakhstan, Belarus and Ukraine.

2015

Five new serial products that have no analogues were launched. Shipping of products all around the world. Participation in the largest exhibitions in Russia: MIPS / Securika (Moscow), INNOPROM (Yekaterinburg), PLUS-Forum (Moscow) and BEZPEKA (Kiev). The company was nominated as “Industry Leader 2017”.

2017

Sheriff was rebranded into Promix. Finalist diploma of the National Award “Not Small Business — 2019” in the nomination “Innovative Breakthrough”. Participation in the international exhibition Securika-2019 (Moscow). Participation in the exhibition in the State Duma of the Russian Federation. Production scale-up — construction of a new production building.

2019

Mission



To be a reliable and technology-savvy partner, to create innovative engineering solutions for safety and convenience!

Promix is a passion for creating engineering solutions that make life more comfortable, convenient, technological and safe.

Activity

Promix is about design and invention.

The main area of the company's activity is development, production and wholesale distribution of automation and access restriction equipment.

The company enjoys its own:

- Design department
- Pilot and serial production
- Technical control department
- Testing laboratory
- Warehouse

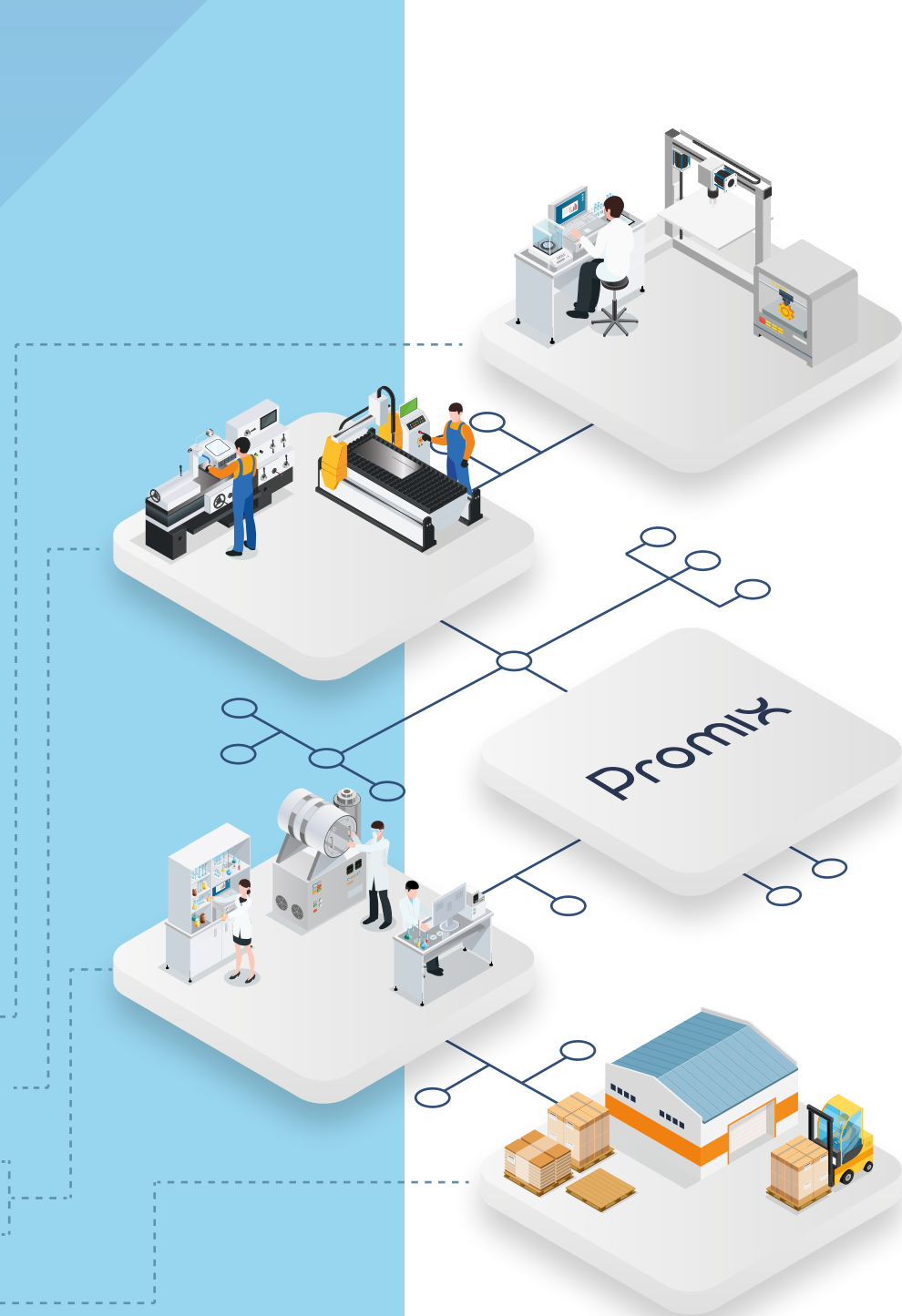

Services and production

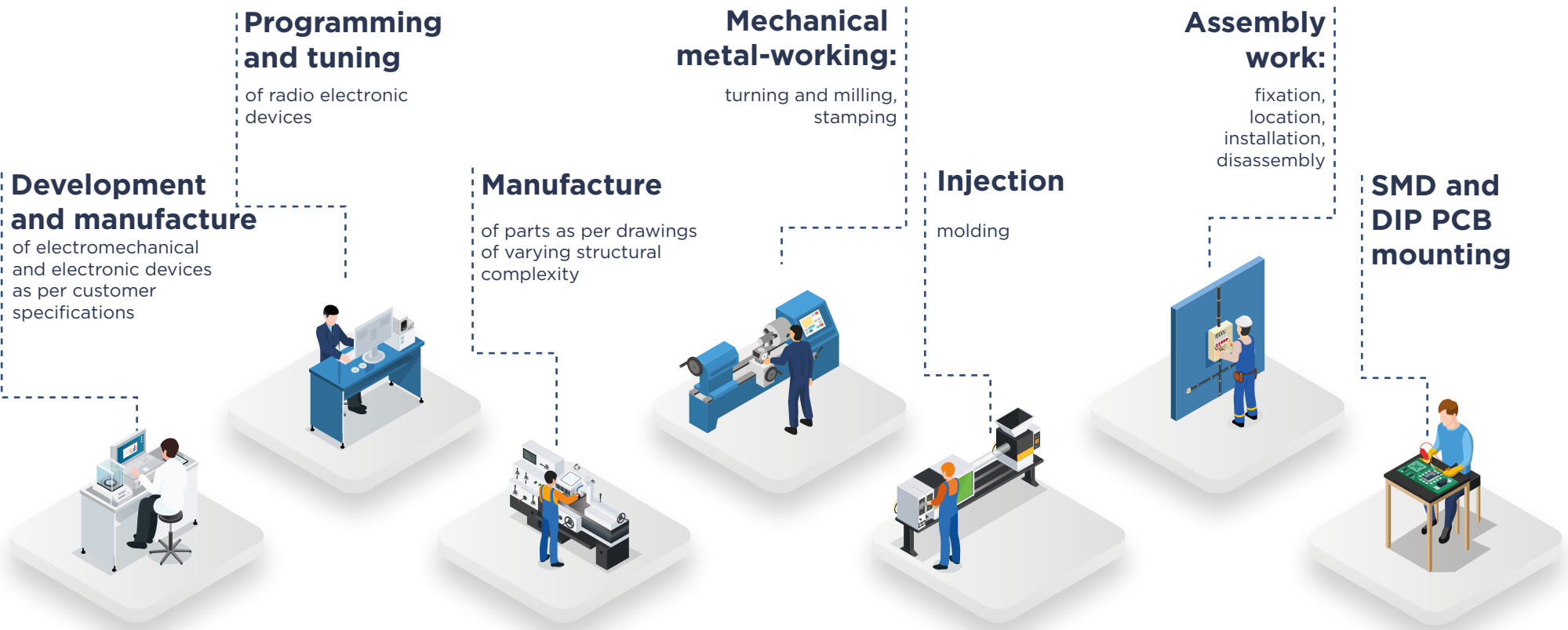

Promix possesses a developed infrastructure, required for comprehensive customer support and a wide range of activities.

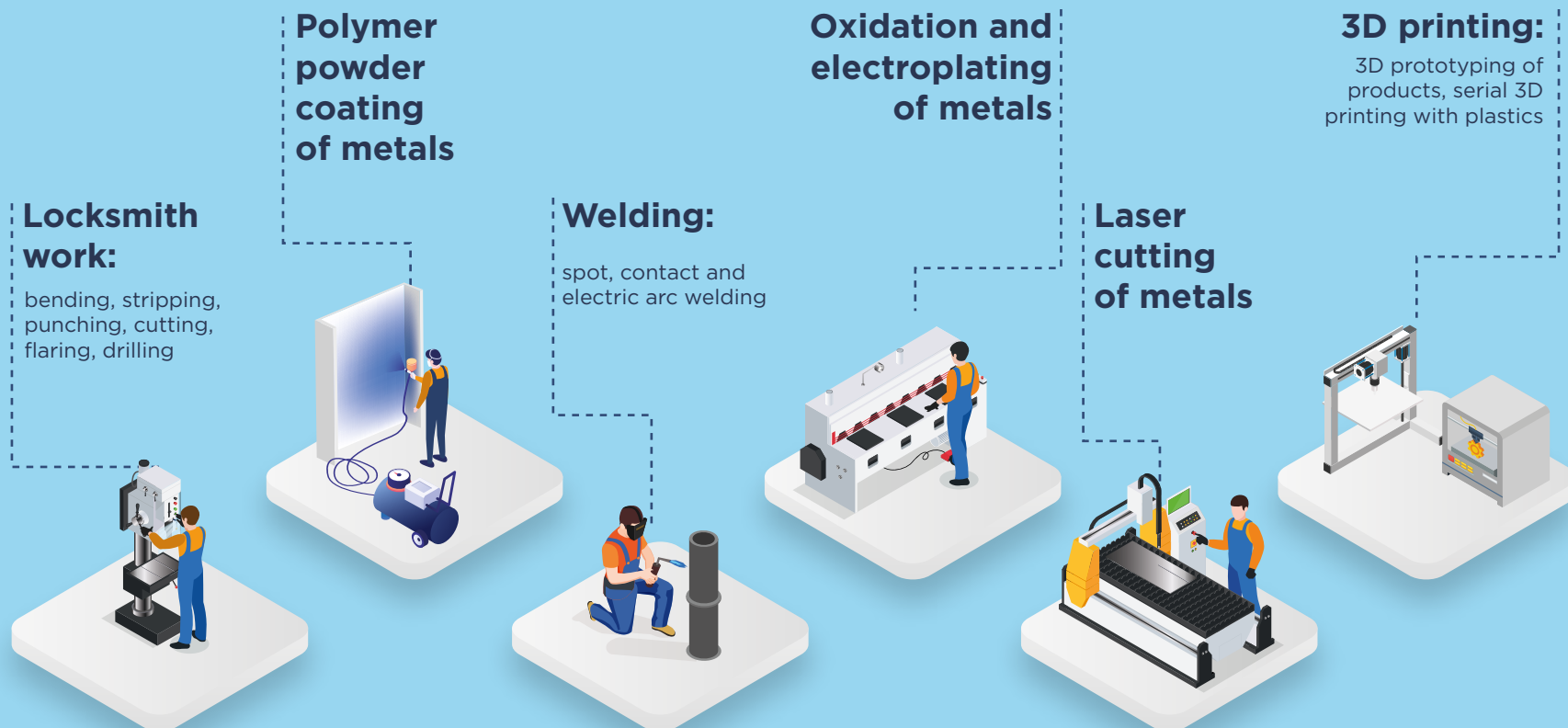

Research and Development

Promix provides the following services as per customer specifications:

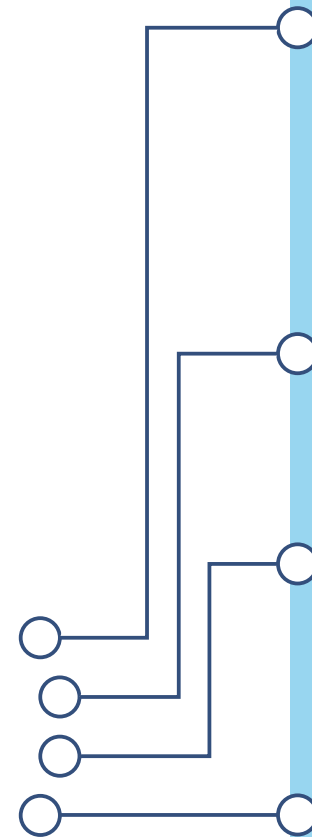

Design and prototyping

Pilot production and product testing

Certification

Preparation of documentation and serial production

You have an idea — we have a solution

Patents

20 registered patents for developed products



Products

The company's product range comprises more than 80 product names that are produced both as series and as per customer specifications.

Our own pilot and serial production facilities in Smolensk

Since 2004 the company has manufactured and sold **more than 1 million items** in Russia, the countries of the Customs Union, CIS and the European Union.

The company manufactures

Electromechanical locks

Controllers

Card readers

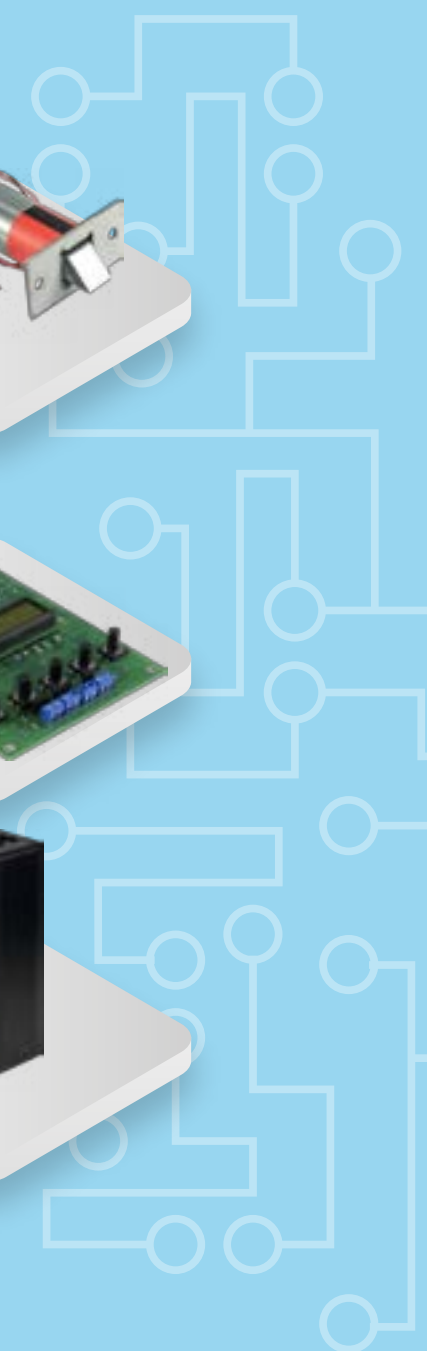
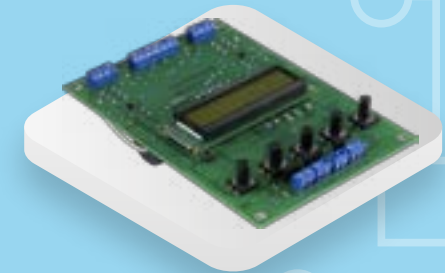
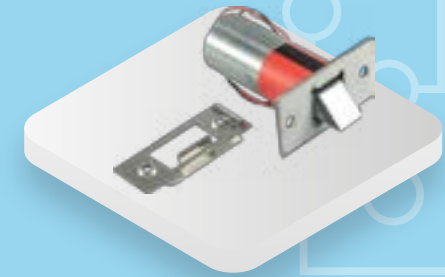

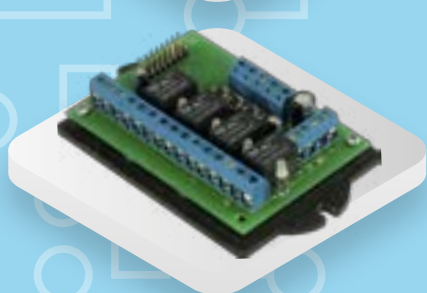

○ — ○ **Heaters**

○ — ○ **Indicators and voice
alarm devices**

○ — ○ **Power supply units
and transformers**

○ — ○ **Other products**

Electromechanical locks

- for doors;
- for gates and wickets;
- for showcases, cabinets and drawers;
- for equipment.

More than 20 lock designs

Promix-SM305



Electromechanical rim lock for plastic doors and windows

Promix-SM213



Mortise electromechanical lock, street variant

Promix-SM102

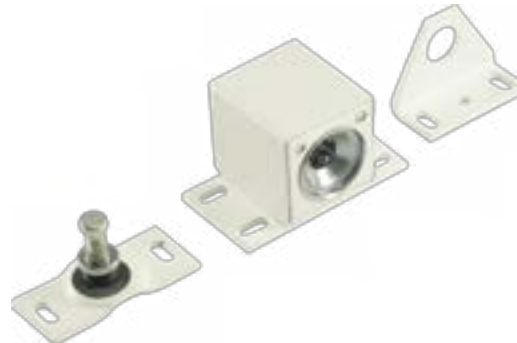

Universal electromechanical mini lock

Promix-SM112



Electromechanical lock for retail space furniture

Electromechanical locks with remote control

- for refrigerated cabinets and showcases
- for chest freezers

Electronic lock for parking of mobile city transport

automated parking for mobile city transport (bicycles, electric scooters, e-bikes)

Promix-FRS.1D.01



Universal electromechanical lock for single-door refrigerator

Promix-SM410



Electromechanical lock with remote control for chest freezer



Promix-SM307



Electronic lock for mobile city transport

Access controllers

- stand-alone controllers
- network controllers
- radio controllers

Promix-CS.PD.01



ATM access controller

Promix-CN.LN.01



LAN controller

Promix-CN.CC.01



Master controller

Promix-RDS.01



Remote control system

Heat controllers

Promix-CT.TMR.01



Electronic defrost timer

Promix-CT.RDK.01



Condensing pressure regulator

Promix-CT.RES.01



Split systems redundancy control unit (rotation system)

Promix-CT.HC.01



Control unit for compressor crankcase heating and split system drainage (seasonal switch)

Card readers

They are part of the **Promix-Bank** system for ATM self-service area access restriction.

More than
5000
self-service areas
throughout Russia

Promix-RR.MC.01



Magnetic stripe card reader

Promix-RR.MC.02



Magnetic stripe card reader in a
vandal resistant housing

Promix-RR.MC.03



Anti-skimming magnetic stripe
card reader in a vandal resistant
housing

Promix-RR.MC.04



Universal card reader for chip
cards (smart cards) and magnetic
stripe cards in a vandal resistant
housing

Heaters

Promix-HT.SR.01



Self-regulating crankcase heater

Promix-HT.SR.02



Self-regulating split system drainage heater

Indicators and voice alarm devices

Promix-VI.LED.01



LED mimic panel "red cross - green arrow"

Promix-VI.VC.02



Voice announcement unit

Promix-VI.DISP.01



Message display unit

Power supply units and transformers

БП-1Н-14-2,0



Unregulated power supply unit for access control systems

БП-1-12-300



Unregulated power supply unit for access control systems

БП-1-5-300



Power supply unit

Other products

Promix-AD.RI.01



Interface repeater

Promix-AD.CI.01



Interface converter ISO-7811 in Wiegand-26

Promix-AD.RM.01



Auxiliary devices control unit

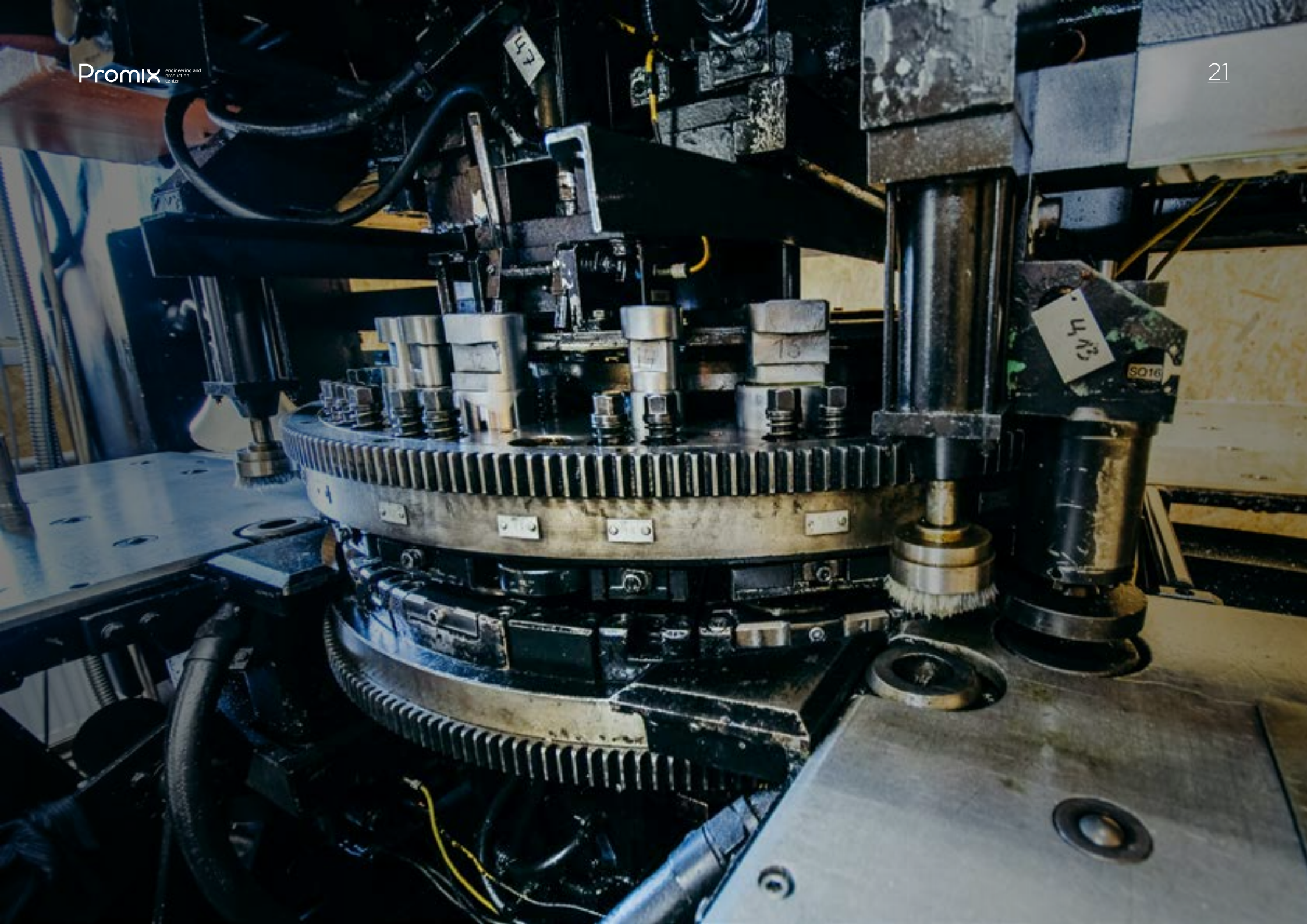

Sales Geography

In order to sell the manufactured equipment and devices, Promix develops and maintains a wholesale and retail network consisting of 47 dealers in Russia, the countries of the Customs Union, CIS and EU.



We work with both large country-wide trading houses and actively developing regional companies.

We conclude long-term contracts with equipment manufacturers directly.

47 dealers

10 reasons to work with us

Flexible pricing

Flexible pricing and **30-day** deferred payment for loyal customers

Experience

The company's experience — **15 years**

Product Warranty — **18 months**

Logistics

Order picking and shipping — from **2 days**

Free reservation of products in our own warehouse for up to **7 days**

Wholesale supply to the countries of the Customs Union, CIS and outside CIS

Worldwide delivery from 1 piece by transport companies Free delivery to the terminal of the transport company

You have an idea — we have a solution

Development and manufacture of products as per customer specifications

Provision of product samples for evaluation and testing for **free**

Over 1,000,000 users of our products

Individual approach to each client

Clients

Electromechanical locks for refrigerated cabinets and freezers



Promix-Bank ATM access restriction system



and other leading Russian banks

Electromechanical locks for parking of mobile city transport



Universal electromechanical locks

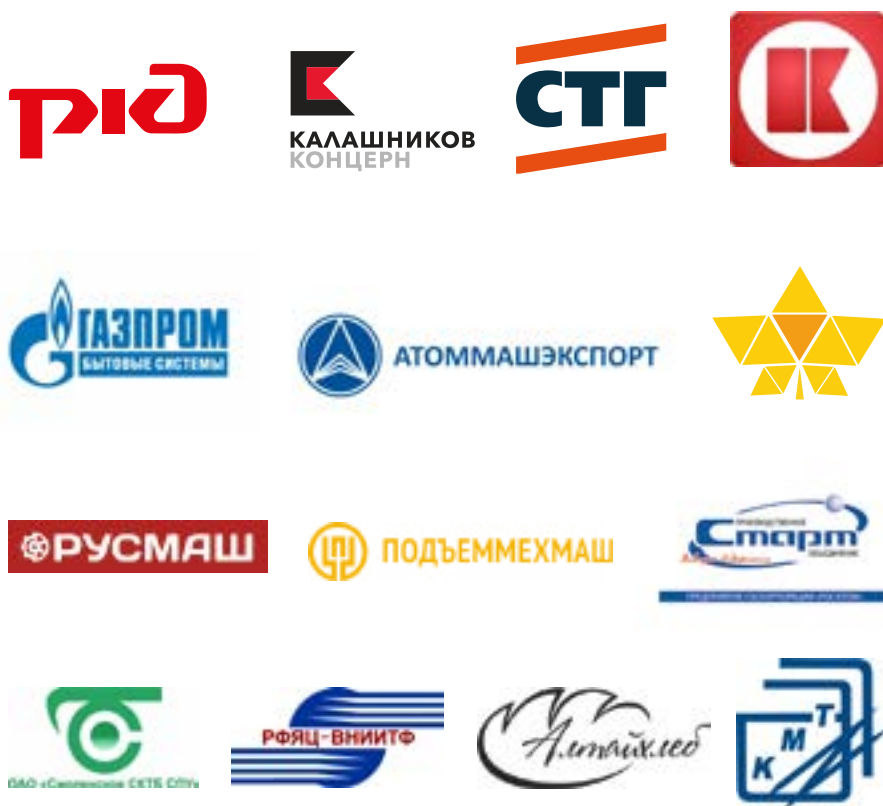

Complete range of products

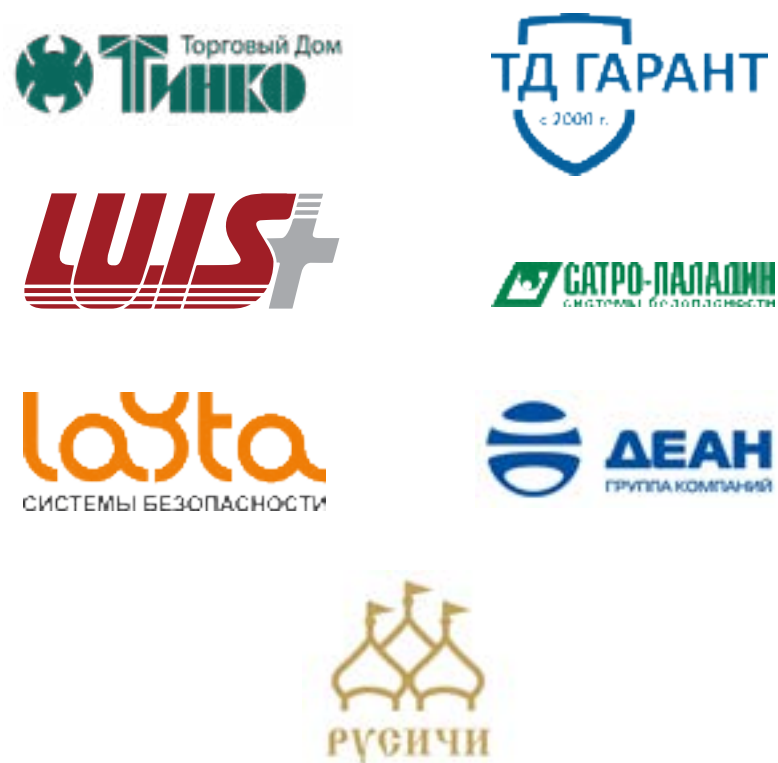

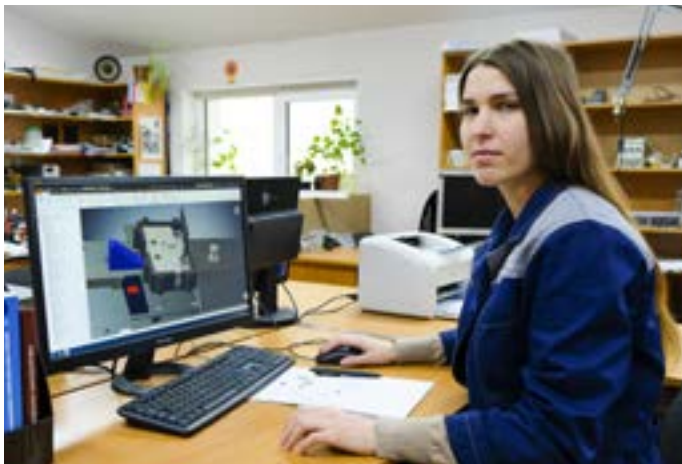

You have an idea —
we have a solution



Promix инженерно-
производственный
центр

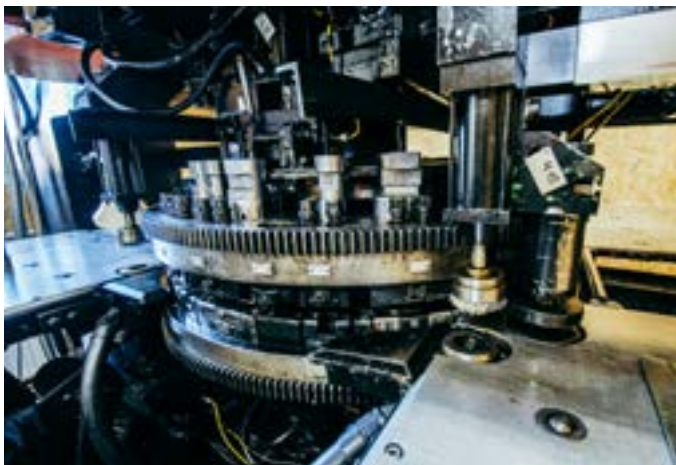

Reliable and
technology-savvy
partner